

TECHNICAL MANUAL

**ORGANIZATIONAL, DIRECT SUPPORT, AND
GENERAL SUPPORT MAINTENANCE
REPAIR PARTS AND SPECIAL TOOLS LISTS**

FOR

**SYNTHESIZER, FUNCTION GENERATOR
(HEWLETT-PACKARD 3325A)**

HEADQUARTERS, DEPARTMENT OF THE ARMY

9 OCTOBER 1984

Technical Manual)
)
 No. 11-6625-3065-24P)

HEADQUARTERS
 DEPARTMENT OF THE ARMY
 Washington, DC, 9 October 1984

ORGANIZATIONAL, DIRECT SUPPORT, AND GENERAL SUPPORT
 MAINTENANCE REPAIR PARTS AND SPECIAL TOOLS LIST
 FOR
 SYNTHESIZER, FUNCTION GENERATOR 3325A (HP)

Current as of 28 June 1984

REPORTING ERRORS AND RECOMMENDING IMPROVEMENTS

You can help improve this manual. If you find any mistakes or if you know of a way to improve the procedures, please let us know. Mail your letter, DA Form 2028 (Recommended Changes to Publications and Blank Forms), or DA Form 2028-2 located in back of this manual direct to: Commander, US Army Communications Electronics Command and Fort Monmouth, ATTN: DRSEL-ME-MP, Fort Monmouth, NJ 07703-5007.

In either case, a reply will be furnished direct to you.

Table of Contents

	Page	Illus Figure
Section I.	Introduction	1
II.	Repair Parts List	5
Group 00	Synthesizer, Function Generator 3325A (HP)5
01	Power Supply Assy 03325-66502 A2 (No parts authorized)	
02	Signal Source Assy 03325-66503 A3 (No parts authorized)	
03	Keyboard Assy 03325-66505 A5 (No parts authorized)	
04	Control Assy 03325-66506 A6 (No parts authorized)	
05	Attenuator Assy 03325-66507 A7 (No parts authorized)	
06	Output Assy, HV 03325-66508 A8 (No parts authorized)	
07	Oven Assy, Crystal 03325-66509 A9 (No parts authorized)	
08	Function Assy 03325-66514 A14	9
09	PC Assy, FFS D/A 03325-66521 A21 (No parts authorized)	
Section III.	Special Tools List (Not applicable)	
IV.	National Stock Number and Part Number Index	10

SECTION I INTRODUCTION

1. Scope

This manual lists spares and repair parts; special tools; special test, measurement, and diagnostic equipment (TMDE), and other special support equipment required for performance of organizational, direct support, and general support maintenance of the 3325A (HP). It authorizes the requisitioning and issue of spares and repair parts as indicated by the source and maintenance codes.

2. General

This Repair Parts and Special Tools List is divided into the following sections:

a. Section II. Repair Parts List. A list of spares and repair parts authorized for use in the performance of maintenance. The list also includes parts which must be removed for replacement of the authorized parts. Parts lists are composed of functional groups in numeric sequence, with the parts in each group listed in figure and item number sequence.

b. Section III. Special Tools List. Not applicable.

c. Section IV. National Stock Number and Part Number Index. A list, in National item identification number (NIIN) sequence, of all National stock numbers (NSN) appearing in the listings, followed by a list, in alphanumeric sequence, of all part numbers appearing in the listings. National stock numbers and part numbers are cross-referenced to each illustration figure and item number appearance.

3. Explanation of Columns

a. Illustration. This column is divided as follows:

- (1) Figure number. Indicates the figure number of the illustration on which the item is shown.
- (2) Item number. The number used to identify item called out in the illustration.

b. Source, Maintenance, and Recoverability (SMR) Codes.

(1) Source code. Source codes indicate the manner of acquiring support items for maintenance, repair, or overhaul of end items. Source codes are entered in the first and second positions of the Uniform SMR Code format as follows:

Code

Definition

PA -- Item procured and stocked for anticipated or known usage.

PB -- Item procured and stocked for insurance purpose because essentially dictates that a minimum quantity be available in the supply system.

<u>Code</u>	<u>Definition</u>
PC --	Item procured and stocked and which otherwise would be coded PA except that it is deteriorative in nature.
PD --	Support item, excluding support equipment, procured for initial issue or outfitting and stocked only for subsequent or additional initial issues or outfittings. Not subject to automatic replenishment.
PE --	Support equipment procured and stocked for initial issue or outfitting to specified maintenance repair activities.
PF--	Support equipment which will not be stocked but which will be centrally procured on demand.
PG --	Item procured and stocked to provide for sustained support for the life of the equipment. It is applied to an item peculiar to the equipment which, because of probable discontinuance or shutdown of production facilities, would prove uneconomical to reproduce at a later time.
KD --	An item of a depot overhaul/repair kit and not purchased separately. Depot kit defined as a kit that provides items required at the time of overhaul or repair.
KF --	An item of a maintenance kit and not purchased separately. Maintenance kit defined as a kit that provides an item that can be replaced at organizational or intermediate levels of maintenance.
KB --	Item included in both a depot overhaul/repair kit and a maintenance kit.
MO--	Item to be manufactured or fabricated at organizational level.
MF --	Item to be manufactured or fabricated at the direct support maintenance level.
MH --	Item to be manufactured or fabricated at the general support maintenance level.
MD --	Item to be manufactured or fabricated at the depot maintenance level.
AO --	Item to be assembled at organizational level.
AF --	Item to be assembled at direct support maintenance level.
AH --	Item to be assembled at general support maintenance level.
AD --	Item to be assembled at depot maintenance level.
XA --	Item is not procured or stocked because the requirements for the item will result in the replacement of the next higher assembly.
XB --	Item is not procured or stocked. If not available through salvage, requisition.

<u>Code</u>	<u>Definition</u>
XC --	Installation drawing, diagram, instruction sheet, field service drawing, that is identified by manufacturer's part number.

XD -- A support item that is not stocked. When required, item will be procured through normal supply channels.

NOTE

Cannibalization or salvage may be used as a source of supply for any items source coded above except those coded XA and aircraft support items as restricted by AR 750-1.

(2) Maintenance code. Maintenance codes are assigned to indicate the levels of maintenance authorized to USE and REPAIR support items. The maintenance codes are entered in the third and fourth positions of the Uniform SMR Code format as follows:

(a) The maintenance code entered in the third position will indicate the lowest maintenance level authorized to remove, replace, and use the support item. The maintenance code entered in the third position will indicate one of the following levels of maintenance.

<u>Code</u>	<u>Application/Explanation</u>
-------------	--------------------------------

C -- Crew or operator maintenance performed within organizational maintenance.

O -- Support item is removed, replaced, used at the organizational level.

F -- Support item is removed, replaced, used at the direct support level.

H -- Support item is removed, replaced, used at the general support level.

D -- Support items that are removed, replaced, used at depot, mobile depot, specialized repair activity only.

(b) The maintenance code entered in the fourth position indicates whether the item is to be repaired and identifies the lowest maintenance level with the capability to perform complete repair (i.e., all authorized maintenance functions). This position will contain one of the following maintenance codes:

<u>Code</u>	<u>Application/Explanation</u>
-------------	--------------------------------

O -- The lowest maintenance level capable of complete repair of the support item is the organizational level.

F -- The lowest maintenance level capable of complete repair of the support item is the direct support level.

H -- The lowest maintenance level capable of complete repair of the support item is the general support level.

<u>Code</u>	<u>Application/Explanation</u>
D --	The lowest maintenance level capable of complete repair of the support item is the depot level.
L --	Repair restricted to designated specialized repair activity.
Z --	Nonreparable. No repair is authorized.
B --	No repair is authorized. The item may be reconditioned by adjusting, lubricating, etc., at the user level. No parts or special tools are procured for the maintenance of this item.

(3) Recoverability code. Recoverability codes are assigned to support items to indicate the disposition action on unserviceable items. The recoverability code is entered in the fifth position of the Uniform SMR Code format as follows:

<u>Recoverability codes</u>	<u>Definition</u>
Z --	Nonreparable item. When unserviceable, condemn and dispose at the level indicated in position 3.
O --	Reparable item. When uneconomically repairable, condemn and dispose at organizational level.
F --	Reparable item. When uneconomically repairable, condemn and dispose at the direct support level.
H --	Reparable item. When uneconomically repairable, condemn and dispose at the general support level.
D --	Reparable item. When beyond lower level repair capability, return to depot. Condemnation and disposal not authorized below depot level.
L --	Reparable item. Repair, condemnation, and disposal not authorized below depot/specialized repair activity level.
A --	Item requires special handling or condemnation procedures because of specific reasons (i.e., precious metal content, high dollar value, critical material or hazardous material). Refer to appropriate manuals/directives for specific instructions.

c. National Stock Number. Indicates the National stock number assigned to the item and will be used for requisitioning purposes.

d. Federal Supply Code for Manufacturer (FSCM). The FSCM is a 5-digit numeric code listed in SB-708-41/42 which is used to identify the manufacturer, distributor, or Government agency, etc.

e. Part Number. Indicates the primary number used by the manufacturer (individual, company, firm, corporation, or Government activity), which controls the

design and characteristics of the item by means of its engineering drawings, specifications, standards, and inspection requirements to identify an item or range of items.

NOTE

When a stock numbered item is requisitioned, the repair part received may have a different part number than the part being replaced.

f. Description. Indicates the Federal item name and, if required, a minimum description to identify the item.

g. Unit of Measure (U/M). Indicates the standard of the basic quantity of the listed item as used in performing the actual maintenance function. This measure is expressed by a two-character alphabetical abbreviation (e.g., ea, in, pr, etc). When the unit of measure differs from the unit of issue, the lowest unit of issue that will satisfy the required units of measure will be requisitioned.

h. Quantity Incorporated in Unit. Indicates the quantity of the item used in the breakout shown on the illustration figure, which is prepared for a functional group, subfunctional group, or an assembly.

4. Special Information

a. The following publication pertains to the 3325A and its components:

TM 11-6625-3065-14, Synthesizer, Function Generator 3325A (HP)

b. National stock numbers (NSN's) that are missing from P source coded items have been applied for and will be added to this TM by future change/revision when they are entered in the Army Master Data File (AMDF). Until the NSN's are established and published, submit exception requisitions to: Commander, US Army Communications-Electronics Command and Fort Monmouth, ATTN: DRSEL-MM, Fort Monmouth, NJ 07703-5007 for the part required to support your equipment.

5. How to Locate Repair Parts

a. When National stock number or part number is unknown.

(1) First. Using the table of contents, determine the functional group within which the item belongs. This is necessary since illustrations are prepared for functional groups and listings are divided into the same groups.

(2) Second. Find the illustration covering the functional group to which the item belongs.

(3) Third. Identify the item on the illustration and note the illustration figure and item number of the item.

(4) Fourth. Using the Repair Parts Listing, find the figure and item number noted on the illustration.

b. When National stock number or part number is known.

(1) First. Using the Index of National Stock Numbers and Part Numbers, find the pertinent National stock number or part number. This index is in NIIN sequence followed by a list of part numbers in alphanumeric sequence, cross-referenced to the illustration figure number and item number.

(2) Second. After finding the figure and item number, locate the figure and item number in the repair parts list.

6. Abbreviations

Not applicable.

(Next printed page is 4.3)

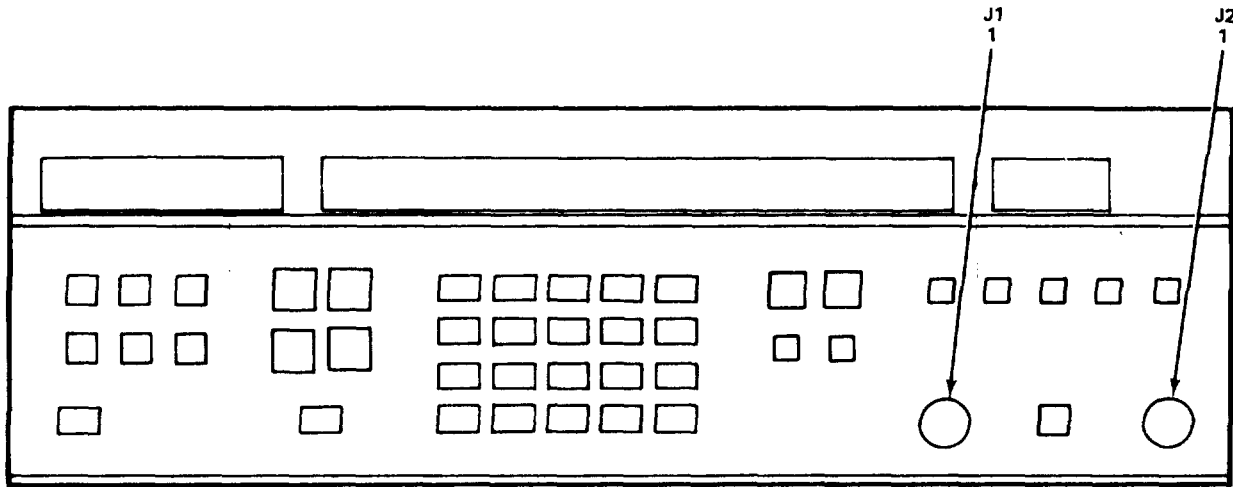

FRONT

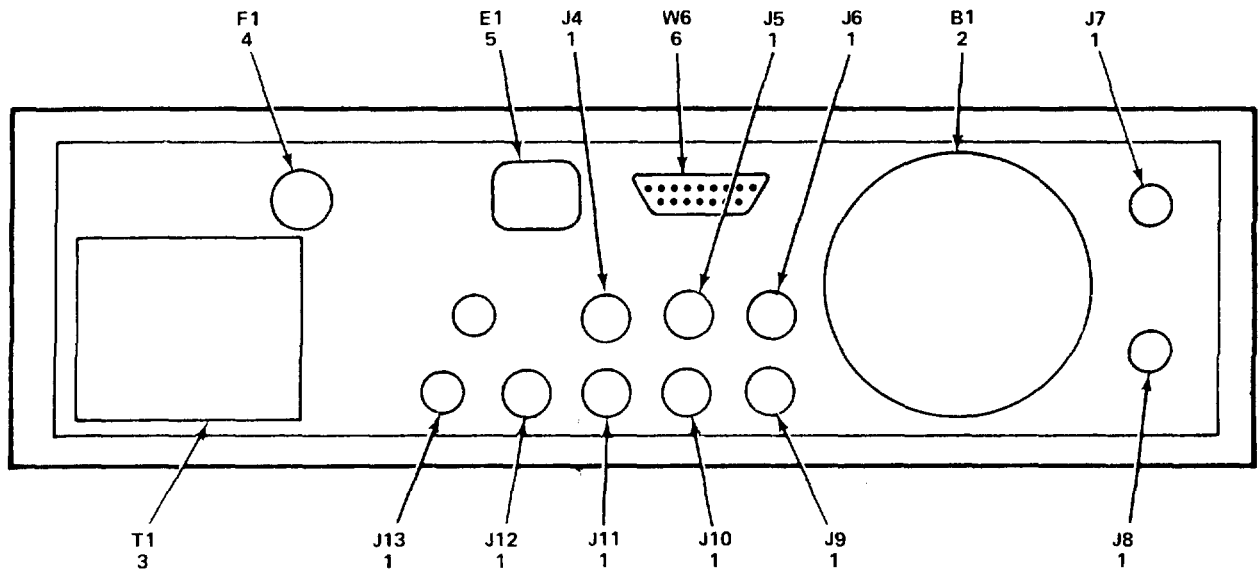

REAR

EL9GZ-1

Figure 1. Synthesizer/Function Generator, 3325A (Sheet 1 of 2)

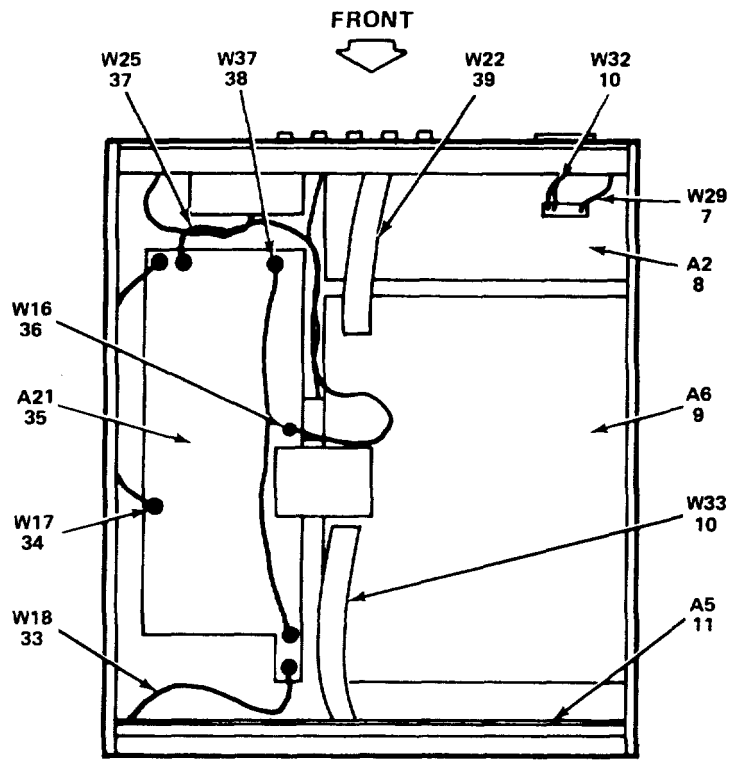

TOP VIEW

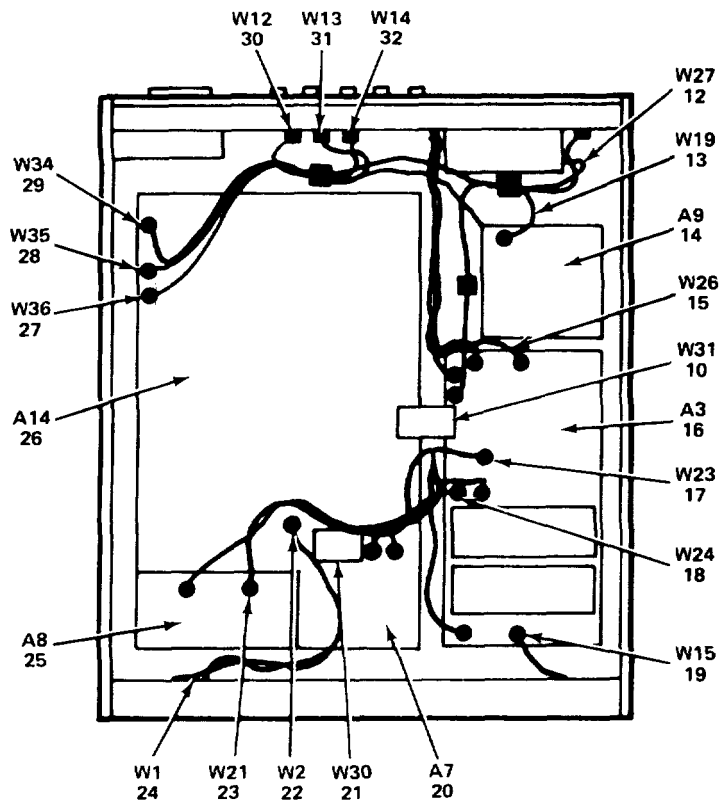

BOTTOM VIEW

EL9GZ-2

Figure 1. Synthesizer/Function Generator, 3325A (Sheet 2 of 2)

SECTION II

(1) Illustration		(2)	(3)	(4)	(5)	(6) Description	(7)	(8) Qty Inc In Unit
(a) Fig No.	(b) Item No.	SMR Code	National Stock Number	FSCM	Part Number	<i>Usable On Code</i>	U/M	
						GROUP 00 SYNTHESIZER, FUNTION GENERATOR 3325A (HP)		
1	1	PAHZZ	5935-01-147-5738	28480	1250-1558	ADAPTER,CONNECTOR	EA	12
1	2	PAHZZ	4140-00-004-9000	28480	3160-0209	FAN,TUBEAXIAL.....	EA	1
1	3	PAHZZ	5950-01-147-0140	28480	9100-4099	TRANSFORMER,POWER	EA	1
1	4	PAHZZ	5920-00-280-8342	75915	312001	FUSE,CARTRIDGE	EA	1
1	5	PAHZZ	6625-01-092-0359	28480	9100-3875	FILTER,POWER LINE	EA	1
1	6	PAHZZ	5995-01-162-5921	28480	8120-2491	CABLE ASSEMBLY	EA	1
1	7	PAHZZ		28680	03325-61616	CABLE ASSEMBLY	EA	1
1	8	PAHDD	6625-01-144-1408	28480	03325-66502	CIRCUIT CARD ASSEMB	EA	1
1	9	PAHDD	6625-01-147-3065	28480	03325-66506	CIRCUIT CARD ASSEMB	EA	1
1	10	PAHZZ	5995-01-162-6907	28480	8120-2577	CABLE ASSEMBLY	EA	3
1	11	PAHDD	6625-01-151-0853	28480	03325-66505	CIRCUIT CARD ASSEMB	EA	1
1	12	PAHZZ	6625-01-143-3414	28480	03325-61614	CABLE ASSEMBLY,SPEC	EA	1
1	13	PAHZZ	5995-01-162-5922	28480	03325-61610	CABLE ASSEMBLY	EA	1
1	14	PAHDD	5895-01-160-4468	28480	03325-66509	CIRCUIT CARD ASSEMB	EA	1
1	15	PAHZZ	6625-01-143-3413	28480	03325-61613	CABLE ASSEMBLY,SPEC	EA	1
1	16	PAHDD	6625-01-141-3063	28480	03325-66503	CIRCUIT CARD ASSEMB	EA	1
1	17	PAHZZ	6625-01-143-0299	28480	03325-61603	CABLE ASSEMBLY,SPEC	EA	1
1	18	PAHZZ	6625-01-143-0300	28480	03375-61618	CABLE ASSEMBLY,SPEC	EA	1
1	19	PAHZZ	6625-01-144-1817	28480	03325-61606	CABLE ASSEMBLY,RADI.....	EA	1
1	20	PAHDD	6625-01-147-3066	28480	03325-66807	CIRCUIT CARD ASSEMB	EA	1
1	21	PAHZZ	5995-01-162-6906	28480	8120-2576	CABLE ASSEMBLY	EA	1
1	22	PAHZZ	5995-01-162-5920	28480	03325-61617	CABLE ASSEMBLY	EA	1
1	23	PAHZZ	5995-01-162-5923	28480	03375-61621	CABLE ASSEMBLY	EA	1
1	24	PAHZZ	5599-01-162-5919	28480	03325-61602	CABLE ASSEMBLY	EA	1
1	25	PAHDD	6625-01-141-3067	28480	03325-66508	CIRCUIT CARD ASSEMB	EA	1
1	26	PAHDD	5895-01-160-4469	28480	03325-66514	CIRCUIT CARD ASS	EA	1
1	27	PAHZZ	5995-01-162-5926	28480	03325-61622	CABLE ASSEMBLY	EA	1
1	28	PAHZZ	5995-01-162-5925	28480	03325-61601	CABLE ASSEMBLY	EA	1
1	29	PAHZZ	6150-00-008-5075	28480	8120-1378	CABLE ASSEMBLY,POWE.....	EA	1
1	30	PAHZZ	6625-01-144-2342	28480	03325-61604	CABLE ASSEMBLY,SPCE	EA	1
1	31	PAHZZ	6625-01-143-3420	28480	03325-61619	CABLE ASSEMBLY,SPEC	EA	1
1	32	PAHZZ	6625-01-144-1816	28480	03325-61620	CABLE ASSEMBLY,RADI	EA	1
1	33	PAHZZ	6625-01-143-0298	28480	03325-61609	CABLE ASSEMBLY,SPEC	EA	1
1	34	PAHZZ	6625-01-143-0297	28480	03328-61608	CABLE ASSEMBLY,SPEC	EA	1
1	35	PAHDD	6625-01-143-3301	28480	03328-66521	CIRCUIT CARD ASSEMB	EA	1
1	36	PAHZZ	6625-01-144-1818	28480	03325-61607	CABLE ASSEMBLY,RADI	EA	1
1	37	PAHZZ	6150-01-162-9622	28480	03325-61612	CABLE ASSEMBLY	EA	1
1	38	PAHZZ	5995-01-162-5927	28480	03325-61623	CABLE ASSEMBLY	EA	1

SECTION II

(1) Illustration		(2)	(3)	(4)	(5)	(6) Description	(7)	(8) Qty Inc In Unit
(a) Fig No.	(b) Item No.	SMR Code	National Stock Number	FSCM	Part Number	<i>Usable On Code</i>	U/M	
1	39	PAHZZ	6625-01-143-0290	28480	03325-61611	CABLE ASSEMBLY,SPEC	EA	1

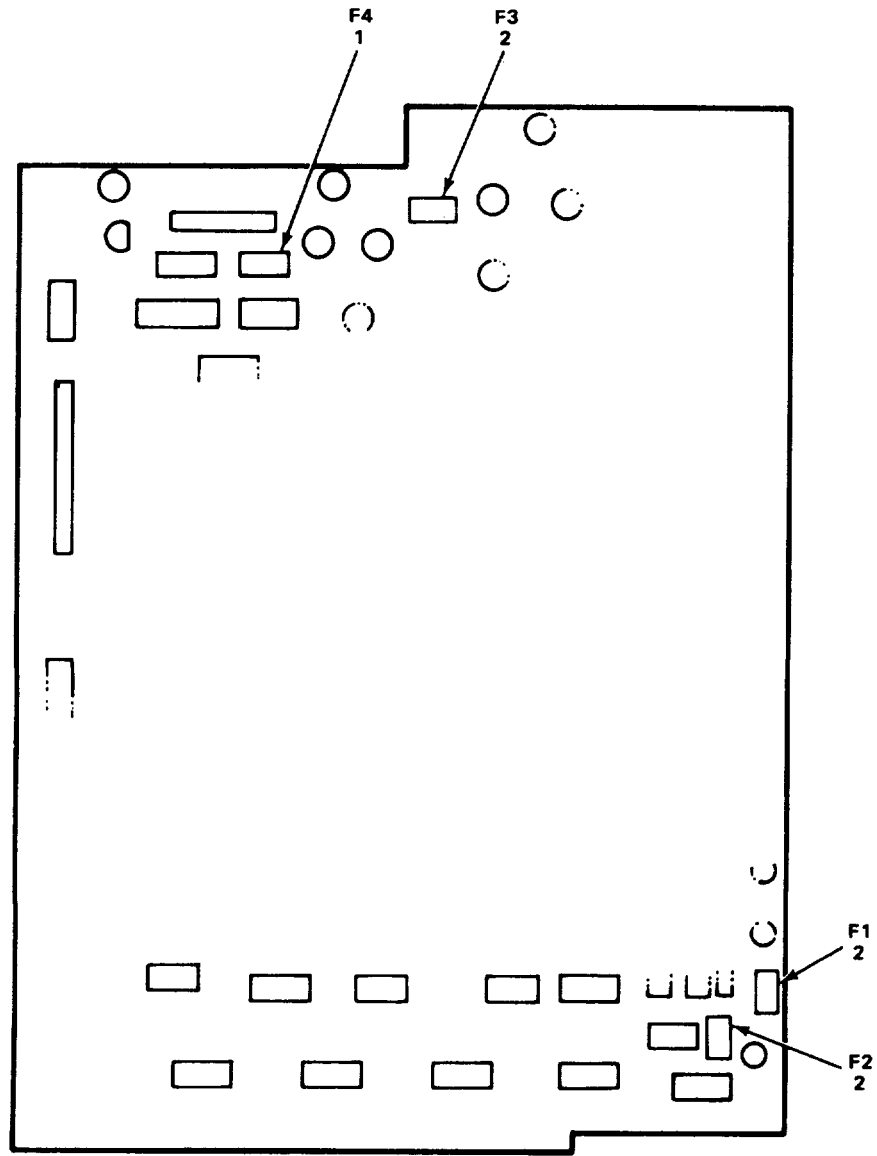

EL9GZ-3

Figure 2. Function Assembly, 03325-66514, A14

SECTION II

(1) Illustration		(2)	(3)	(4)	(5)	(6) Description	(7)	(8) Qty Inc In Unit
(a) Fig No.	(b) Item No.	SMR Code	National Stock Number	FSCM	Part Number	<i>Usable On Code</i>	U/M	
2	1	PAHZZ	5920-01-073-1231	28480	2110-0301	GROUP 01 FUNTION ASSY 03325-66514 A14		
						FUSE,CARTRIDGE	EA	1
2	2	PAHZZ		28480	2110-0343	FUSE	EA	3

SECTION IV

NATIONAL STOCK NUMBER AND PART NUMBER INDEX

TM 11-6625-3065-24P

STOCK NUMBER	FIGURE NO.	ITEM NO.	STOCK NUMBER	FIGURE NO.	ITEM NO.
4140-00-004-9000	1	2	6625-01-147-3063	1	16
6150-00-008-5075	1	29	6625-01-147-3065	1	9
5920-00-280-8342	1	4	6625-01-147-3066	1	20
5920-01-073-1231	2	1	6625-01-147-3067	1	25
6625-01-092-0359	1	5	5935-01-147-5738	1	1
6625-01-143-0290	1	39	6625-01-151-0853	1	11
6625-01-143-0297	1	34	5895-01-160-4468	1	14
6625-01-143-0298	1	33	5895-01-160-4469	1	26
6625-01-143-0299	1	17	5995-01-162-5919	1	24
6625-01-143-0300	1	18	5995-01-162-5920	1	22
6625-01-143-3301	1	35	5995-01-162-5921	1	6
6625-01-143-3413	1	15	5995-01-162-5922	1	13
6625-01-143-3414	1	12	5995-01-162-5923	1	23
6625-01-143-3420	1	31	5995-01-162-5925	1	28
6625-01-144-1408	1	8	5995-01-162-5926	1	27
6625-01-144-1816	1	32	5995-01-162-5927	1	38
6625-01-144-1817	1	19	5995-01-162-6906	1	21
6625-01-144-1818	1	36	5995-01-162-6907	1	10
6625-01-144-2342	1	30	6150-01-162-9622	1	37
5950-01-147-0140	1	3			

FSCM	PART NUMBER	FIG. NO.	ITEM NO.	FSCM	PART NUMBER	FIG. NO.	ITEM NO.
28480	03325-61601	1	28	28480	03325-66502	1	8
28480	03325-61602	1	24	28480	03325-66503	1	16
28480	03325-61603	1	17	28480	03325-66505	1	11
28480	03325-61604	1	30	28480	03325-66506	1	9
28480	03325-61606	1	19	28480	03325-66507	1	20
28480	03325-61607	1	36	28480	03325-66508	1	25
28480	03325-61608	1	34	28480	03325-66509	1	14
28480	03325-61609	1	33	28480	03325-66514	1	26
28480	03325-61610	1	13	28480	03325-66521	1	35
28480	03325-61611	1	39	28480	1250-1558	1	1
28480	03325-61612	1	37	28480	2110-0301	2	1
28480	03325-61613	1	15	28480	2110-0343	2	2
28480	03325-61614	1	12	75915	312001	1	4
28480	03325-61616	1	7	28480	3160-0209	1	2
28480	03325-61617	1	22	28480	8120-1378	1	29
28480	03325-61618	1	18	28480	8120-2491	1	6
28480	03325-61619	1	31	28480	8120-2576	1	21
28480	03325-61620	1	32	28480	8120-2577	1	10
28480	03325-61621	1	23	28480	9100-3875	1	5
28480	03325-61622	1	27	28480	9100-4099	1	3
28480	03325-61623	1	38				

By Order of the Secretary of the Army:

JOHN A. WICKHAM JR.
General, United States Army
Chief of Staff

Official:

ROBERT M. JOYCE
Major General, United States Army
The Adjutant General

Distribution:

To be distributed in accordance with special list.

RECOMMENDED CHANGES TO EQUIPMENT TECHNICAL PUBLICATIONS



THEN...JOT DOWN THE
DOPE ABOUT IT ON THIS FORM.
CAREFULLY TEAR IT OUT, FOLD IT
AND DROP IT IN THE MAIL.

SOMETHING WRONG WITH PUBLICATION

FROM: (PRINT YOUR UNIT'S COMPLETE ADDRESS)

DATE SENT

PUBLICATION NUMBER

PUBLICATION DATE

PUBLICATION TITLE

BE EXACT PIN-POINT WHERE IT IS

PAGE
NO.

PARA-
GRAPH

FIGURE
NO.

TABLE
NO.

IN THIS SPACE, TELL WHAT IS WRONG
AND WHAT SHOULD BE DONE ABOUT IT.

TEAR ALONG PERFORATED LINE

PRINTED NAME, GRADE OR TITLE AND TELEPHONE NUMBER

SIGN HERE

The Metric System and Equivalents

Linear Measure

1 centimeter = 10 millimeters = .39 inch
 1 decimeter = 10 centimeters = 3.94 inches
 1 meter = 10 decimeters = 39.37 inches
 1 dekameter = 10 meters = 32.8 feet
 1 hectometer = 10 dekameters = 328.08 feet
 1 kilometer = 10 hectometers = 3,280.8 feet

Weights

1 centigram = 10 milligrams = .15 grain
 1 decigram = 10 centigrams = 1.54 grains
 1 gram = 10 decigrams = .035 ounce
 1 dekagram = 10 grams = .35 ounce
 1 hectogram = 10 dekagrams = 3.52 ounces
 1 kilogram = 10 hectograms = 2.2 pounds
 1 quintal = 100 kilograms = 220.46 pounds
 1 metric ton = 10 quintals = 1.1 short tons

Liquid Measure

1 centiliter = 10 milliliters = .34 fl. ounce
 1 deciliter = 10 centiliters = 3.38 fl. ounces
 1 liter = 10 deciliters = 33.81 fl. ounces
 1 dekaliter = 10 liters = 2.64 gallons
 1 hectoliter = 10 dekaliters = 26.42 gallons
 1 kiloliter = 10 hectoliters = 264.18 gallons

Square Measure

1 sq. centimeter = 100 sq. millimeters = .155 sq. inch
 1 sq. decimeter = 100 sq. centimeters = 15.5 sq. inches
 1 sq. meter (centare) = 100 sq. decimeters = 10.76 sq. feet
 1 sq. dekameter (are) = 100 sq. meters = 1,076.4 sq. feet
 1 sq. hectometer (hectare) = 100 sq. dekameters = 2.47 acres
 1 sq. kilometer = 100 sq. hectometers = .386 sq. mile

Cubic Measure

1 cu. centimeter = 1000 cu. millimeters = .06 cu. inch
 1 cu. decimeter = 1000 cu. centimeters = 61.02 cu. inches
 1 cu. meter = 1000 cu. decimeters = 35.31 cu. feet

Approximate Conversion Factors

To change	To	Multiply by	To change	To	Multiply by
inches	centimeters	2.540	ounce-inches	newton-meters	.007062
feet	meters	.305	centimeters	inches	.394
yards	meters	.914	meters	feet	3.280
miles	kilometers	1.609	meters	yards	1.094
square inches	square centimeters	6.451	kilometers	miles	.621
square feet	square meters	.093	square centimeters	square inches	.155
square yards	square meters	.836	square meters	square feet	10.764
square miles	square kilometers	2.590	square meters	square yards	1.196
acres	square hectometers	.405	square kilometers	square miles	.386
cubic feet	cubic meters	.028	square hectometers	acres	2.471
cubic yards	cubic meters	.765	cubic meters	cubic feet	35.315
fluid ounces	milliliters	29.573	cubic meters	cubic yards	1.308
pints	liters	.473	milliliters	fluid ounces	.034
quarts	liters	.946	liters	pints	2.113
gallons	liters	3.785	liters	quarts	1.057
ounces	grams	28.349	liters	gallons	.264
pounds	kilograms	.454	grams	ounces	.035
short tons	metric tons	.907	kilograms	pounds	2.205
pound-feet	newton-meters	1.356	metric tons	short tons	1.102
pound-inches	newton-meters	.11296			

Temperature (Exact)

°F	Fahrenheit temperature	5/9 (after subtracting 32)	Celsius temperature	°C
----	------------------------	----------------------------	---------------------	----

PIN: 056658-000